

University of South Carolina Callcott Social Science Roof Replacement

Drawing Index

- T-1 Title Sheet
- R-1 Roof Plan - Existing Conditions
- R-2 Roof Plan - New
- D-1 Roof Details
- D-2 Roof Details
- S1.0 Safety Anchor Plan

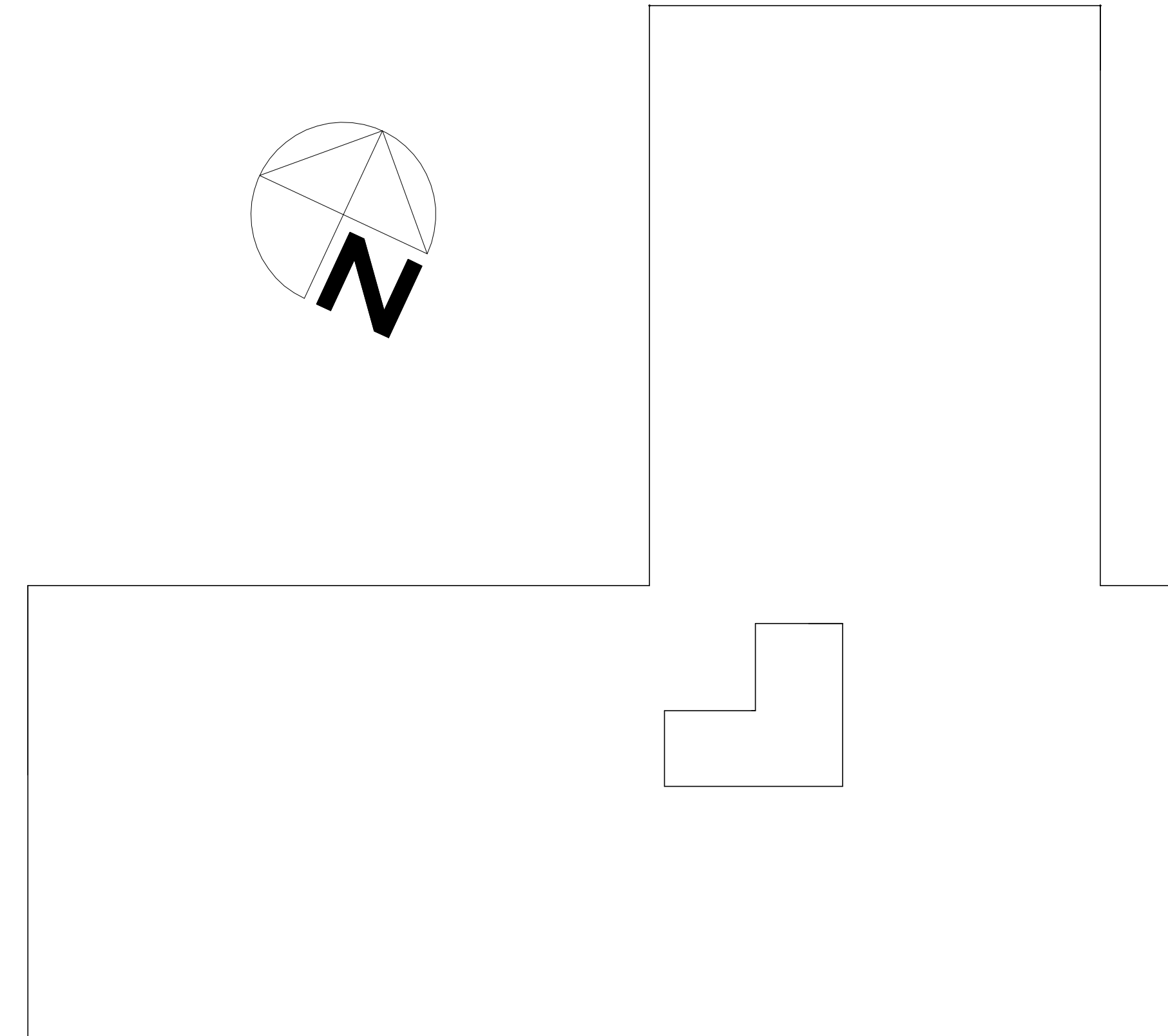
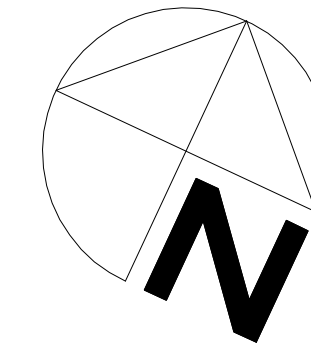

Callcott Social Science Building
709 Bull Street
Columbia, South Carolina

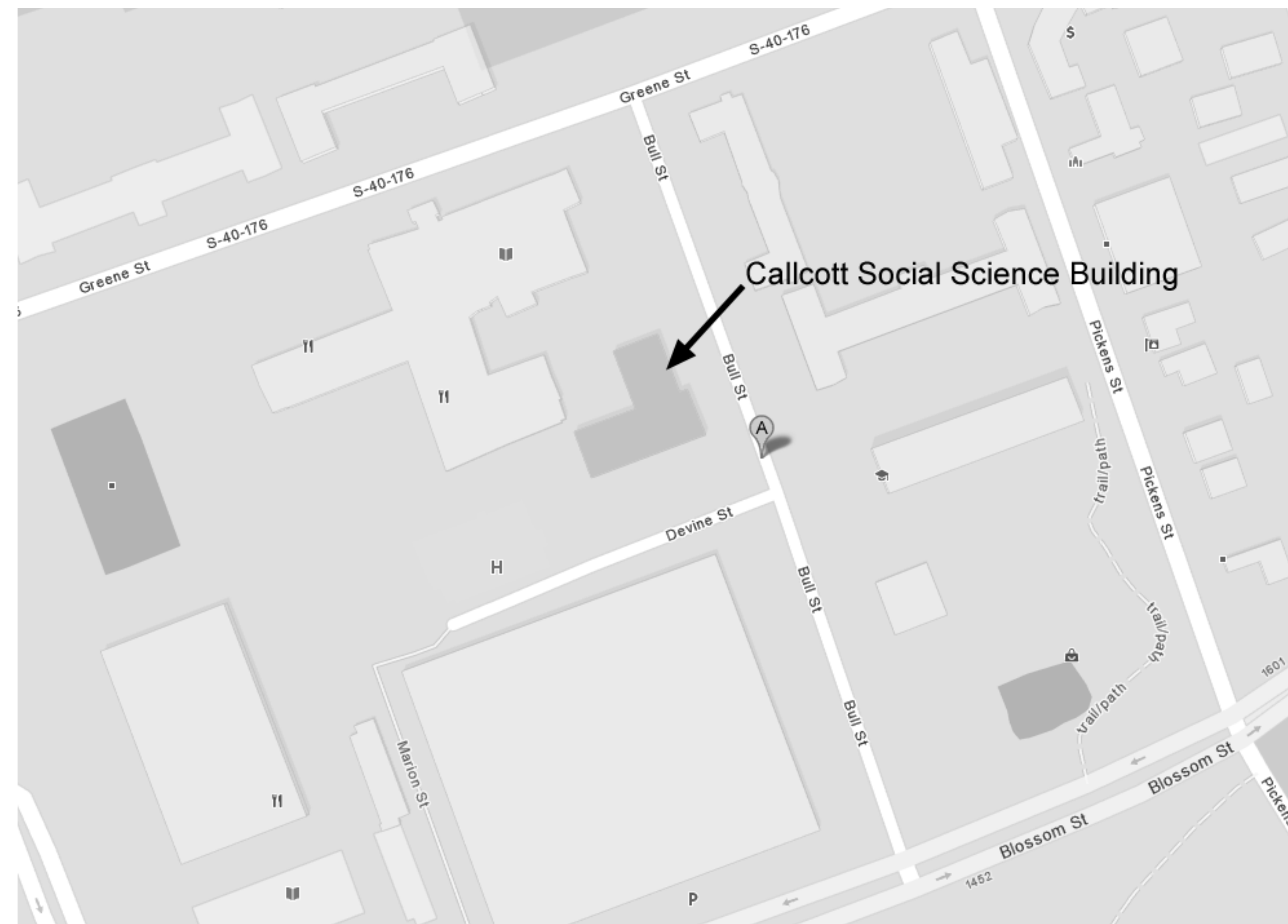

Notes:

No.	Revision/Issue	Date
		10/13

University of
South Carolina
Callcott Social
Science
Roof Replacement
(H27-6100-B)

T-1
(Title Page)

Prepared by
Lyon & Associates
Roofing and Waterproofing
Consultants

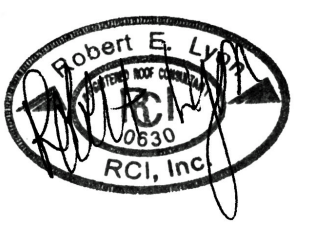





Date	10/2013	Sheet	1 of 5
Scale	Not to Scale		

General Notes

- 1) Roof top equipment and drain locations are approximate
- 2) Contractor's are responsible for all measurements

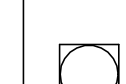
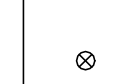
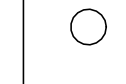
Contractor Notes:

Legend

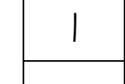
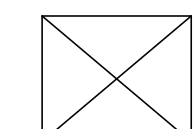
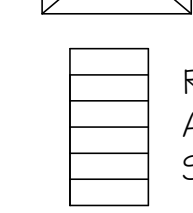
-  Gravity Vent
-  Roof Drain
-  Stack Vent
-  Lightning Rod
-  Pitch Pan
-  Plumbing Vent
-  Wood Conduit Support
-  Curb
-  Roof Access Stairs

1		10/13
No.	Revision/Issue	Date

University of
South Carolina
Callcott Social
Science
Roof Replacement
(H27-6100-B)

R-1
(EXISTING)

Prepared by
Lyon & Associates
Roofing and Waterproofing
Consultants

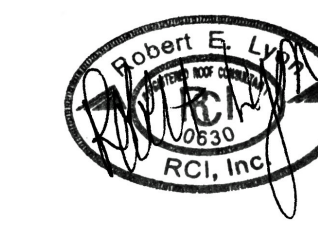

Date	10/2013	Sheet	2 of 5
Scale	Not to Scale		

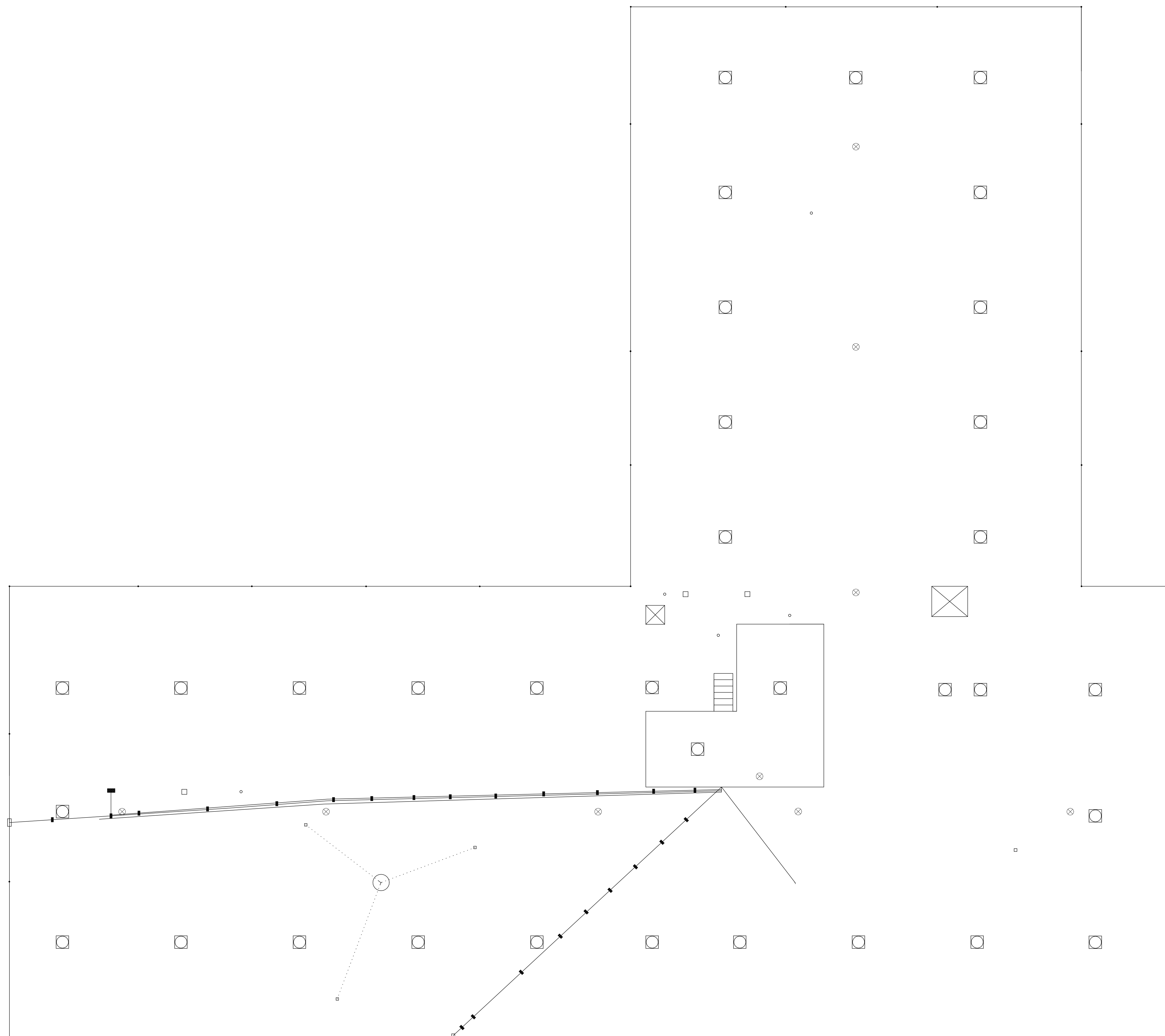

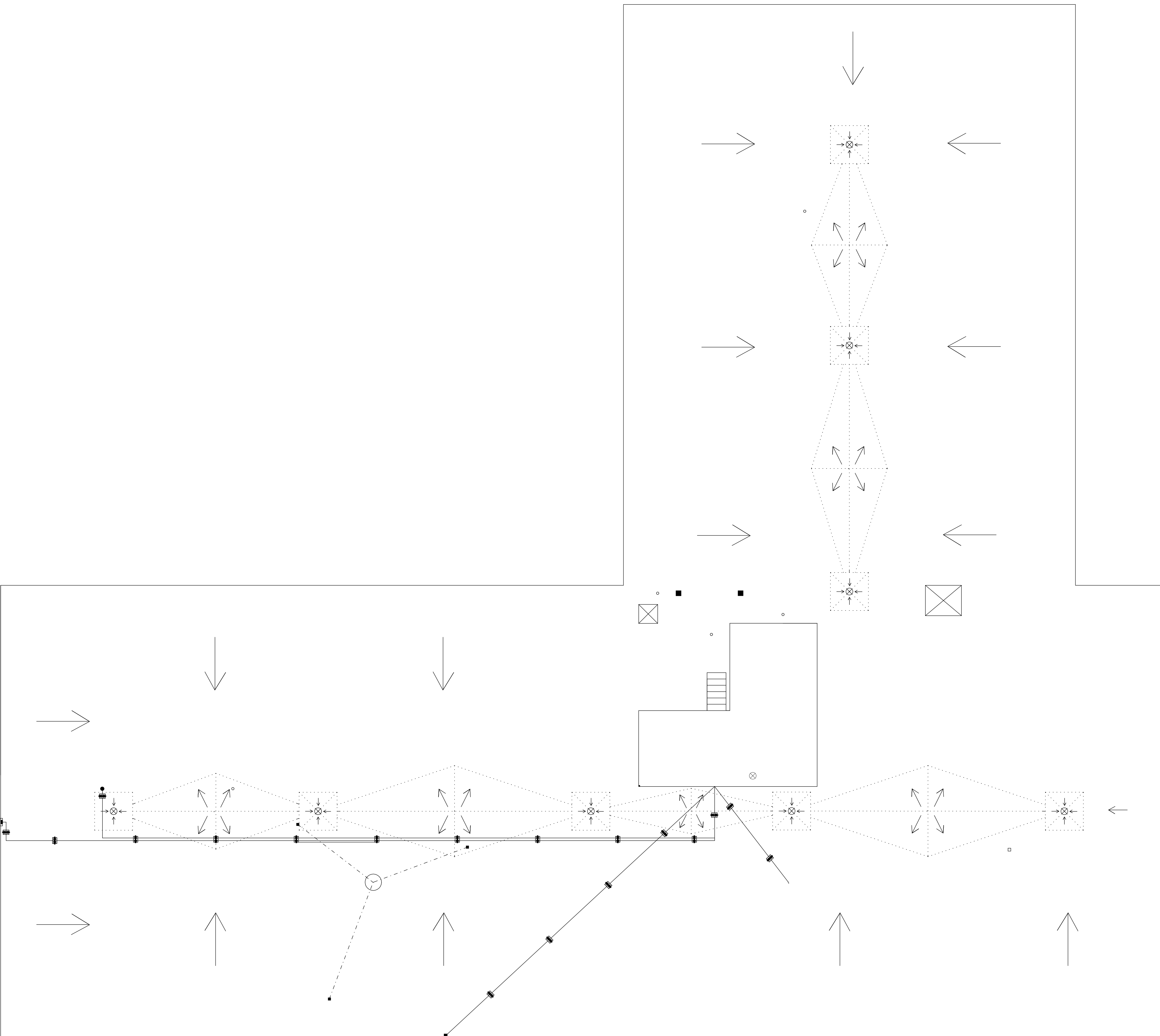

General Notes

- 1) Roof top equipment and drain locations are approximate
- 2) Contractor's are responsible for all measurements
- 3) Insulation cricket length to width ratio is 3:1. Cricket slope is double that of roof slope
- 4) Existing roof drains may require lowering in order to achieve proper sump. Sump size: 4' x 4'
- 5) Roof top security lighting is to be flashed with pitch pan and sheet metal hood
- 6) 110 power outlet is to be supported with new stand

Contractor Notes:

Legend

- Sumped Roof Drain
- Stack Vent
- Lightning Rod
- Conduit Support
- Pitch Pan
- Plumbing Vent
- 110 Power Outlet
- Curb
- Roof Access Stairs

1		10/13
No.	Revision/Issue	Date

University of
South Carolina
Callcott Social
Science
Roof Replacement
(H27-6100-B)

R-2
(NEW)

Prepared by
Lyon & Associates
Roofing and Waterproofing
Consultants

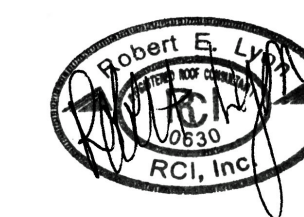

Date	10/2013	Sheet	3 of 5
Scale	Not to Scale		

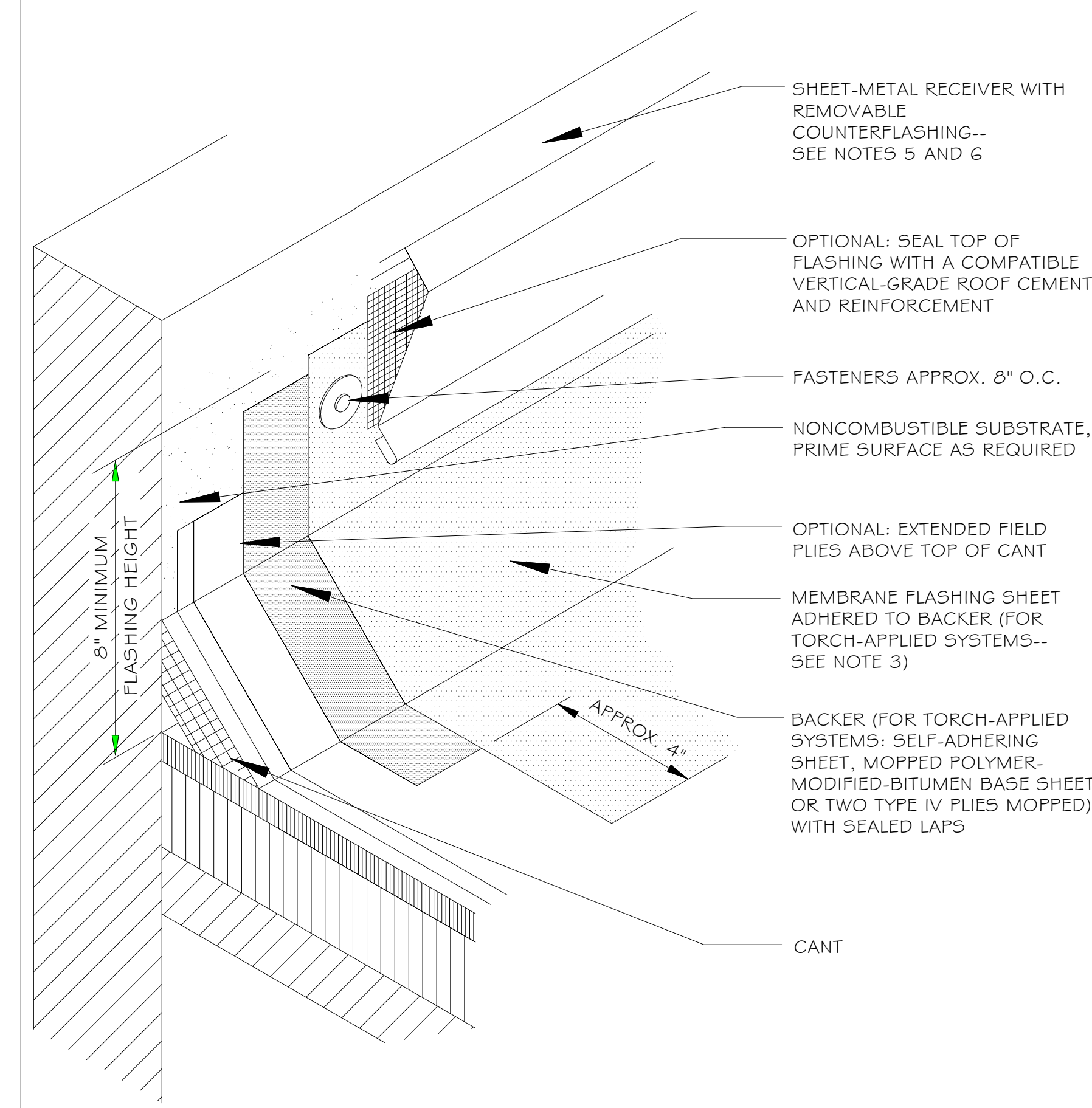

BASE FLASHING WITH TWO-PIECE SHEET-METAL COUNTERFLASHING

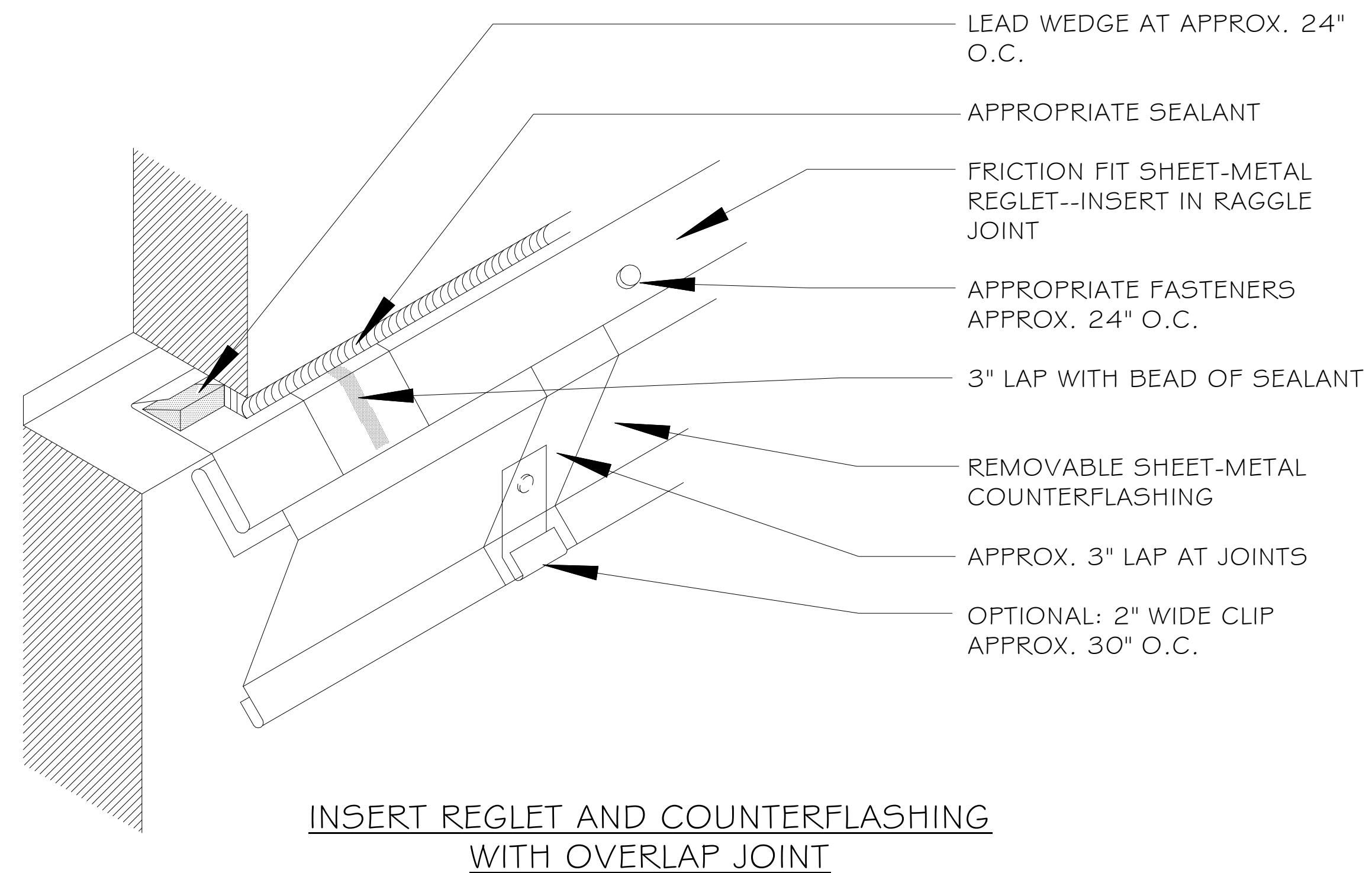

COUNTERFLASHING

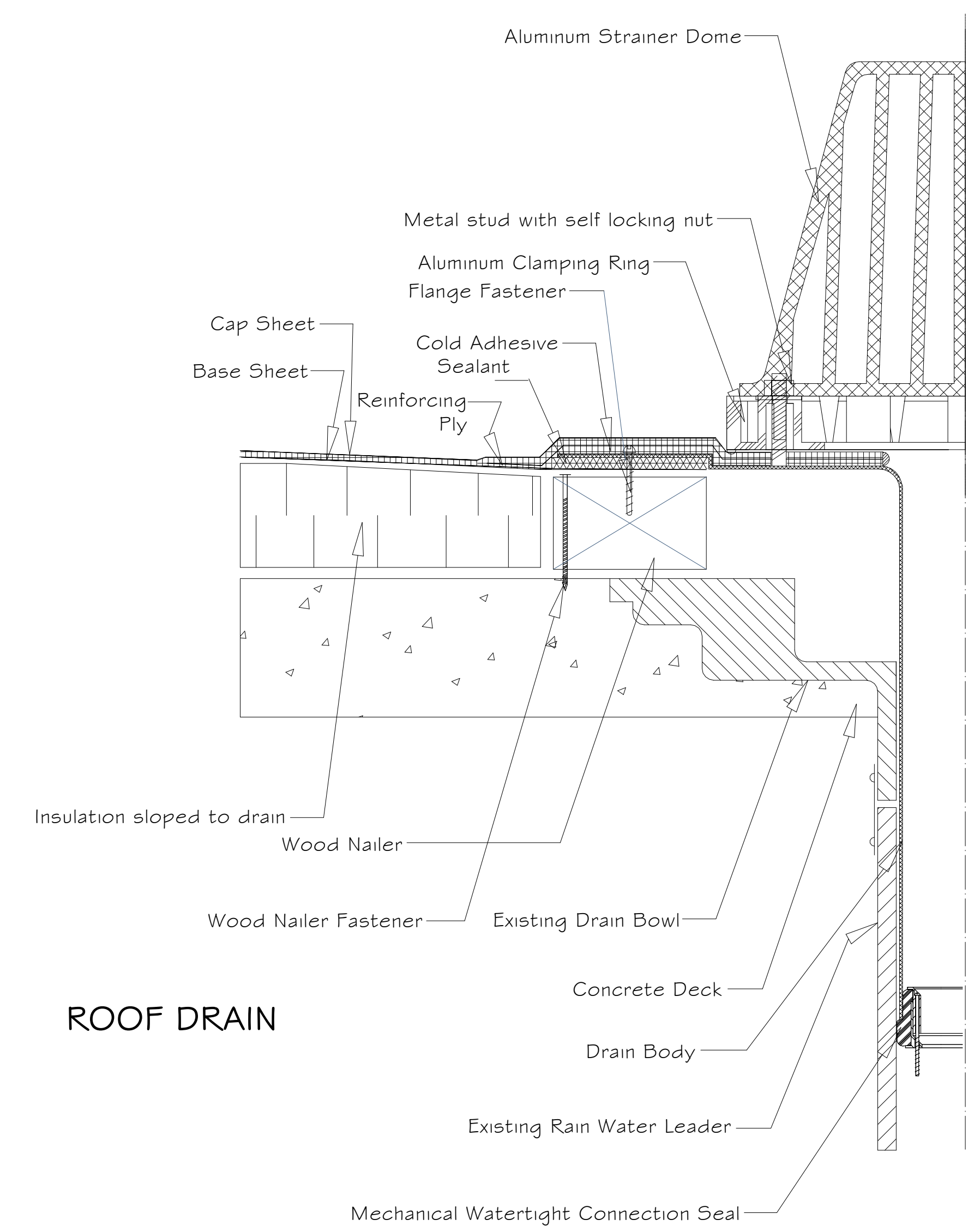

ROOF DRAIN

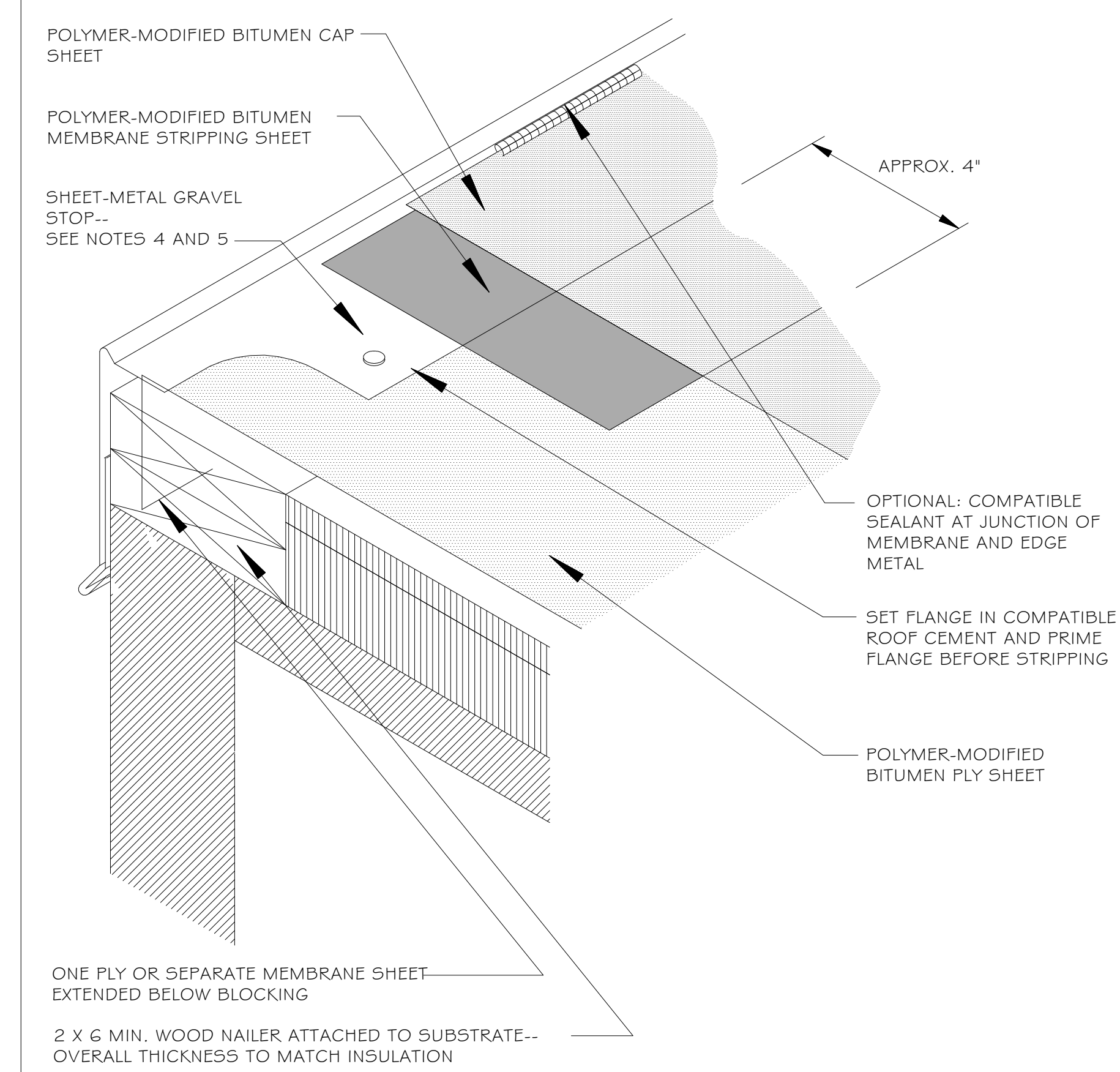

EMBEDDED EDGE METAL FLASHING

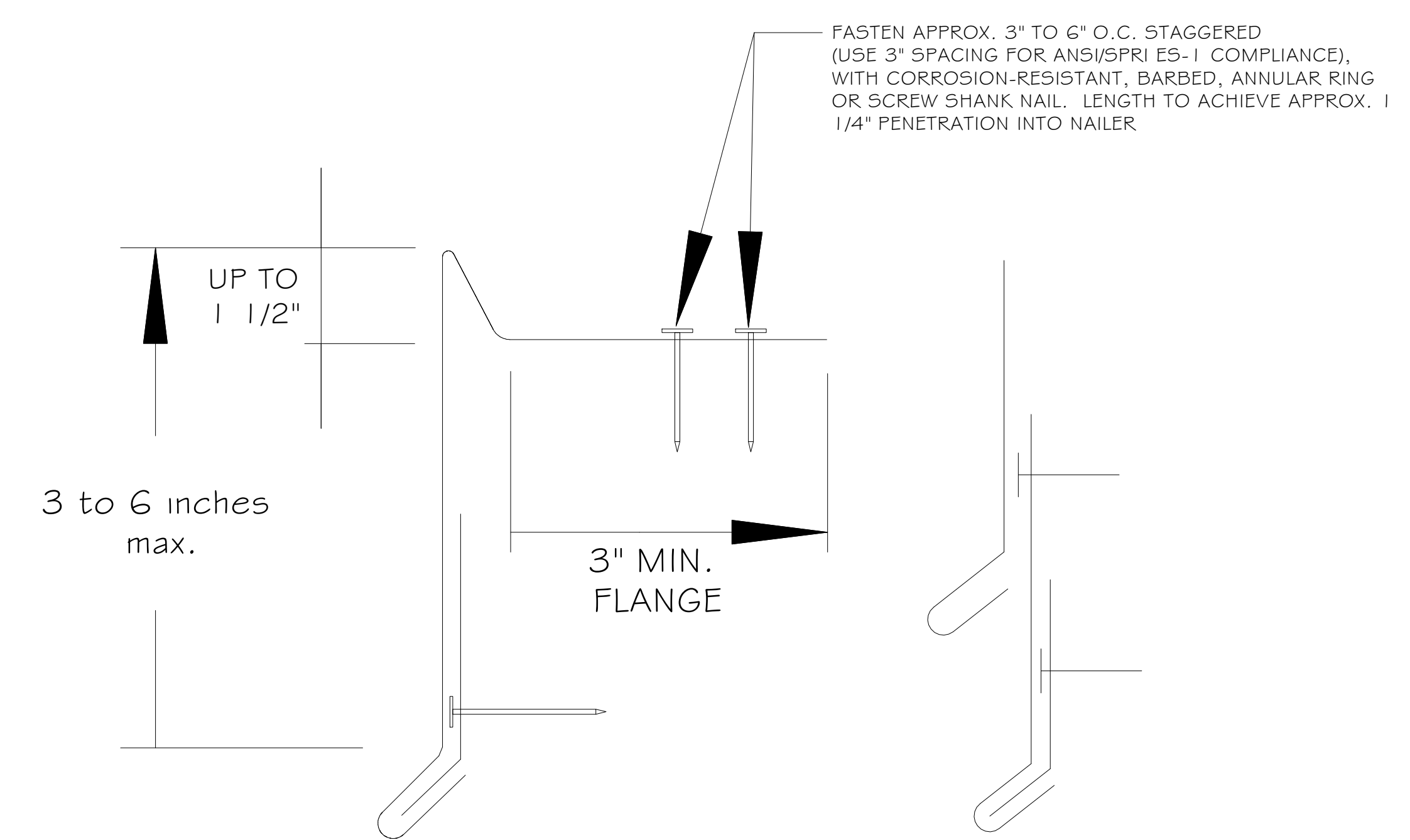

FASCIA EXTENSION

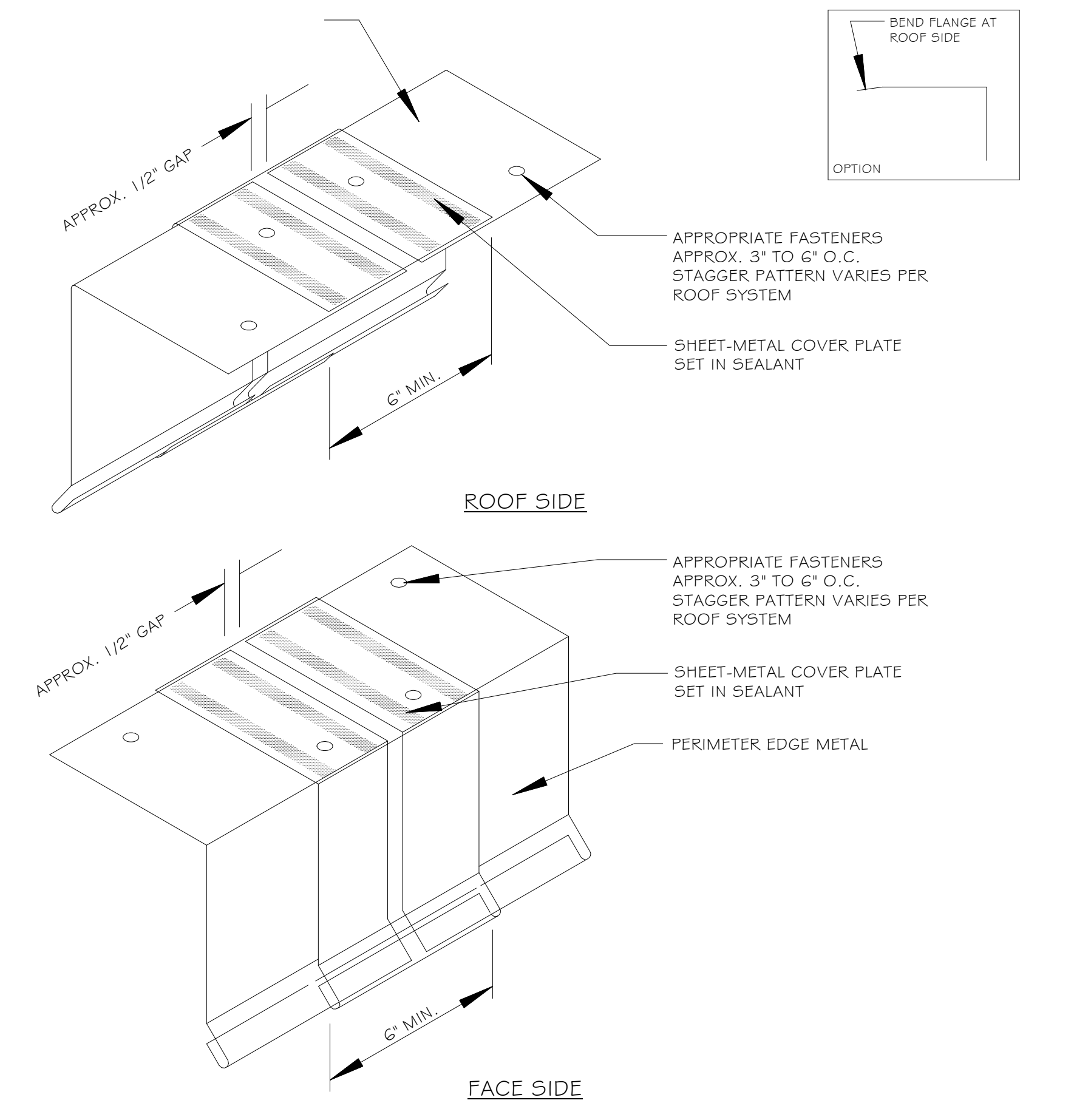

PERIMETER EDGE METAL WITH COVER PLATE

EMBEDDED EDGE (A-TYPE)
PERIMETER EDGE-METAL SECUREMENT AND FASCIA EXTENSION

I		10/13
No.	Revision/Issue	Date

University of South Carolina
Callcott Social Science
Roof Replacement (H27-6100-B)

D-1
(Roof Details)

Prepared by
Lyon & Associates
Roofing and Waterproofing
Consultants

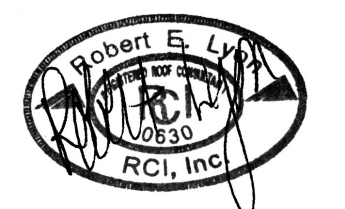

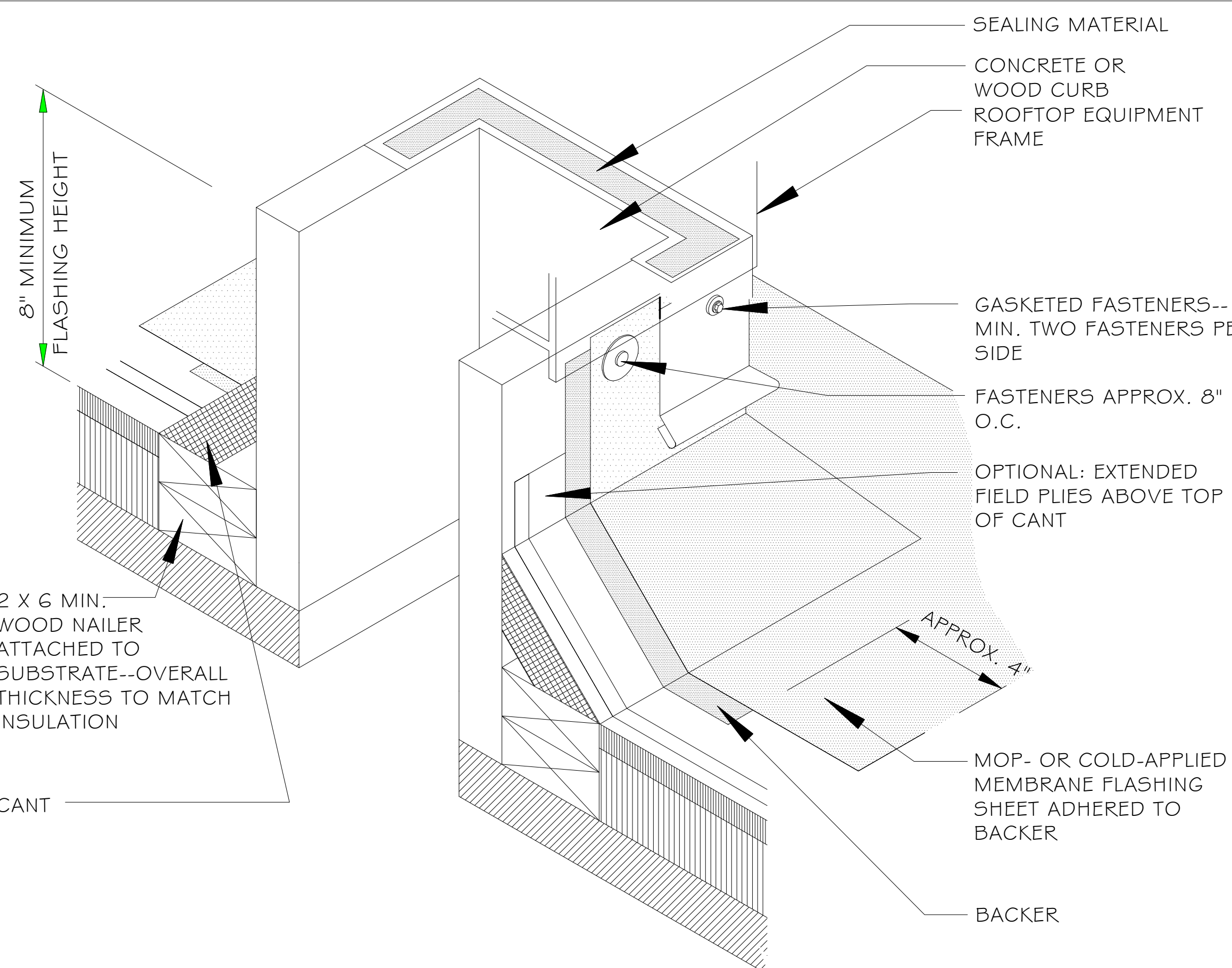

BASE FLASHING AT CURB LOCATIONS

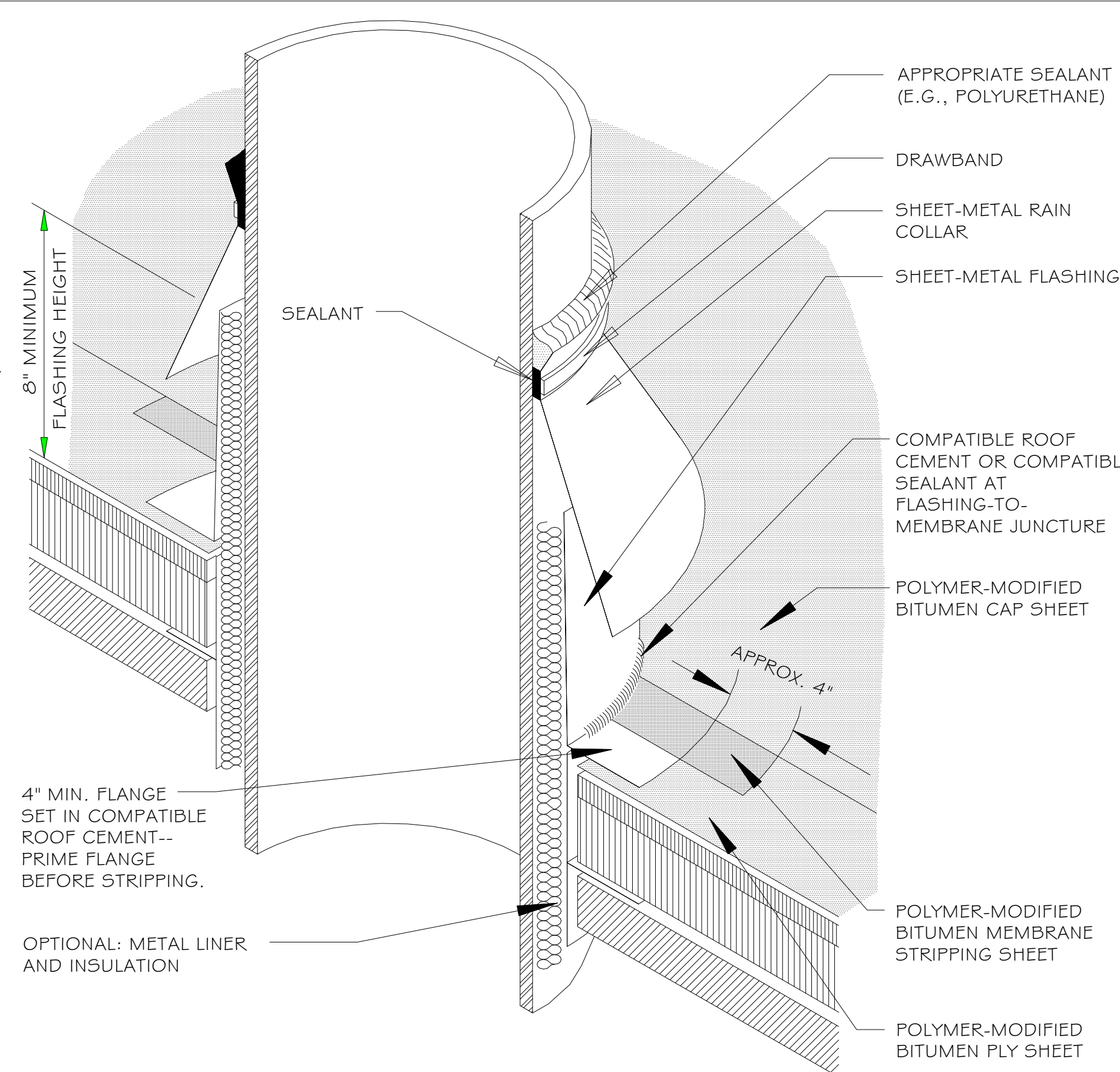

SHEET-METAL STACK VENT

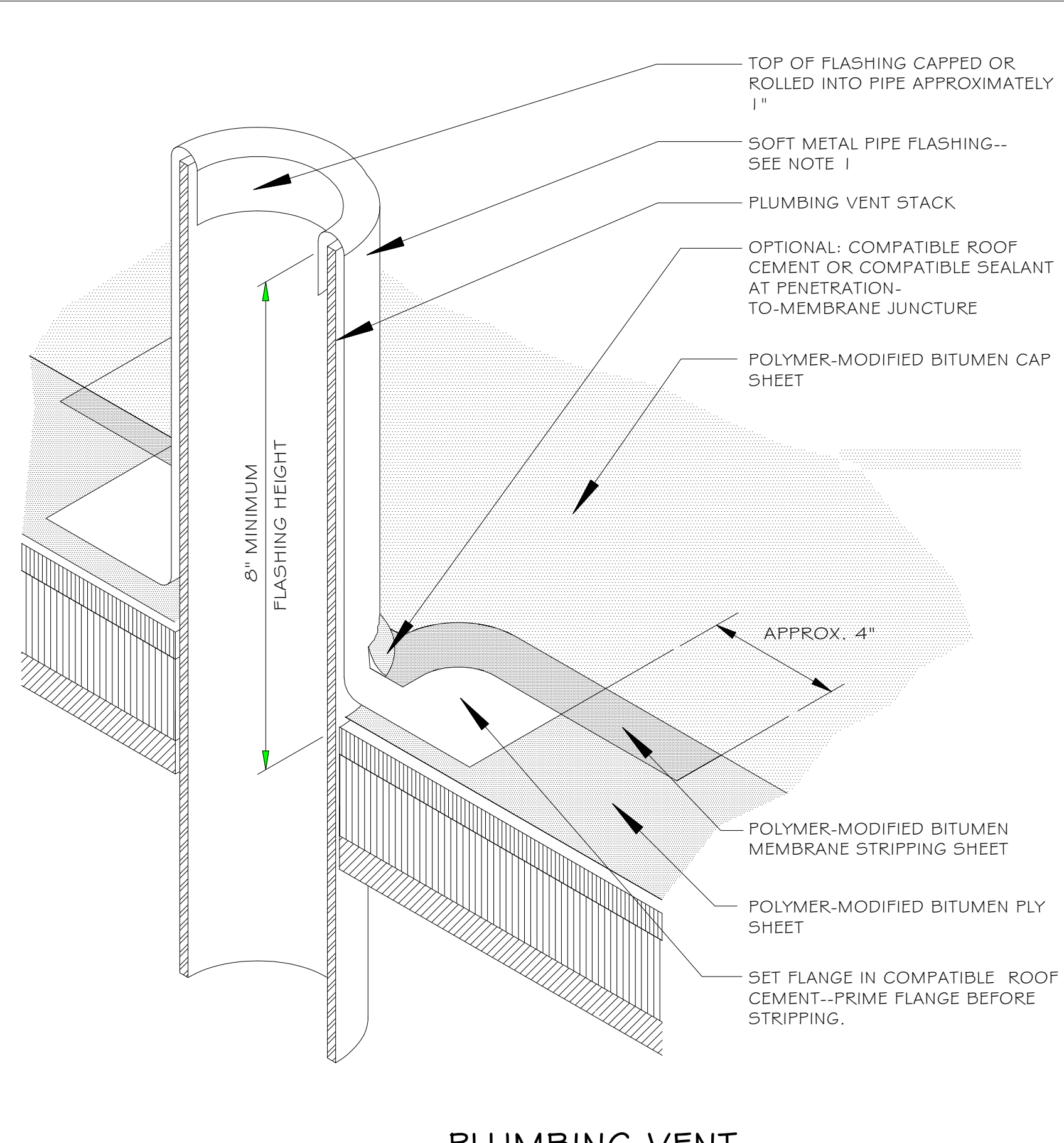

PLUMBING VENT

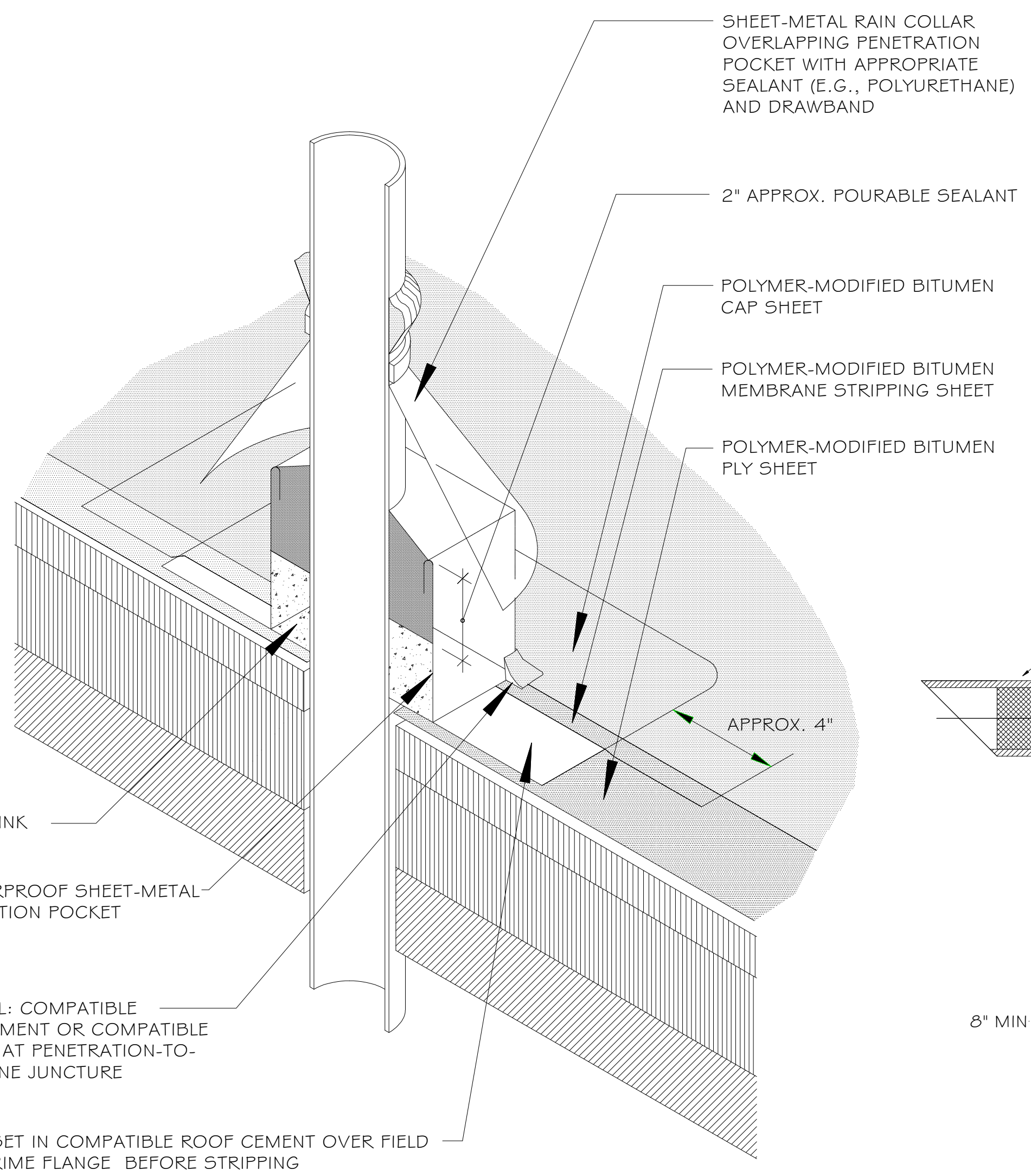

PENETRATION POCKET--SINGLE PENETRATION

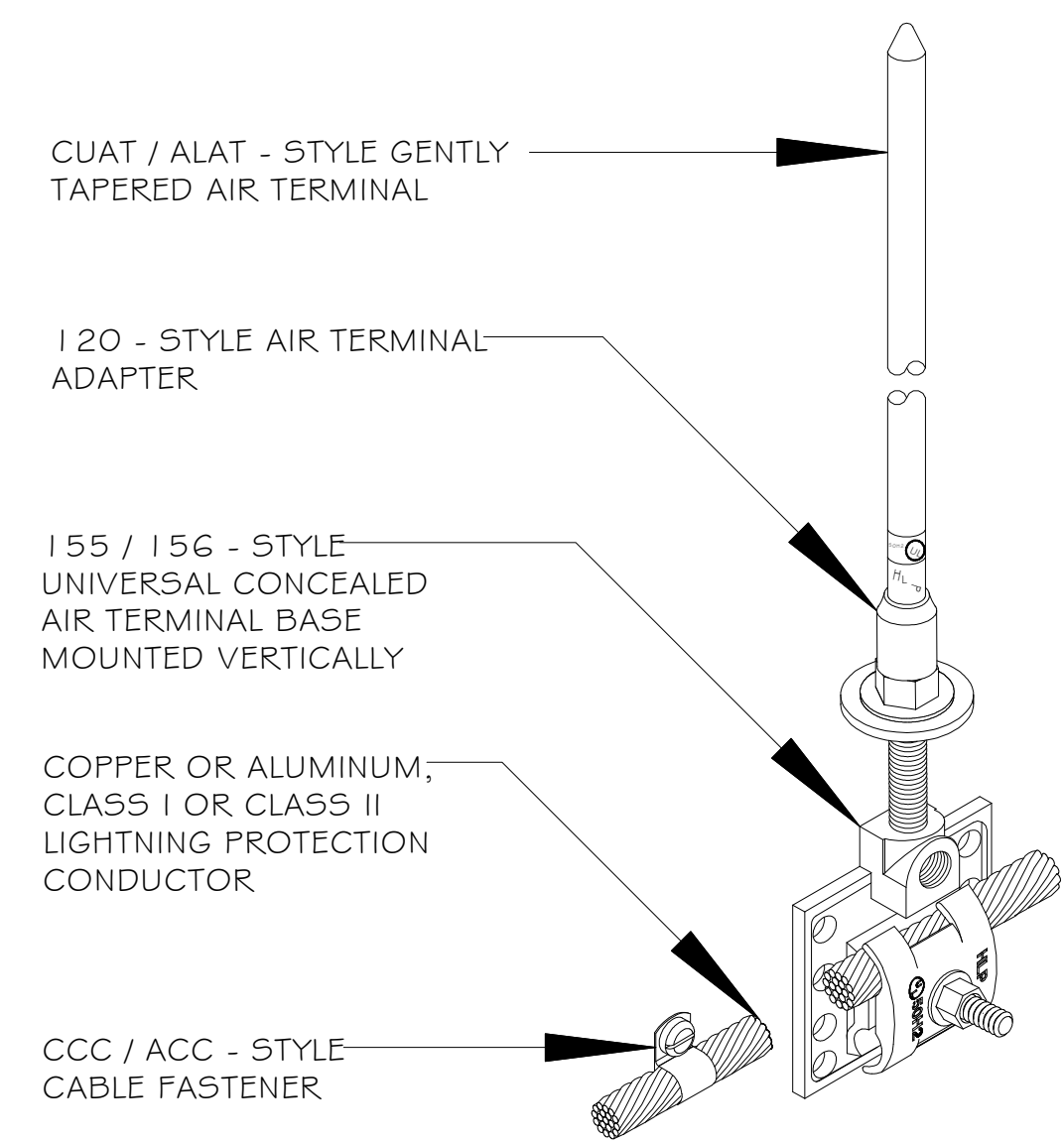

WALL MOUNTED LIGHTNING PROTECTION TERMINAL

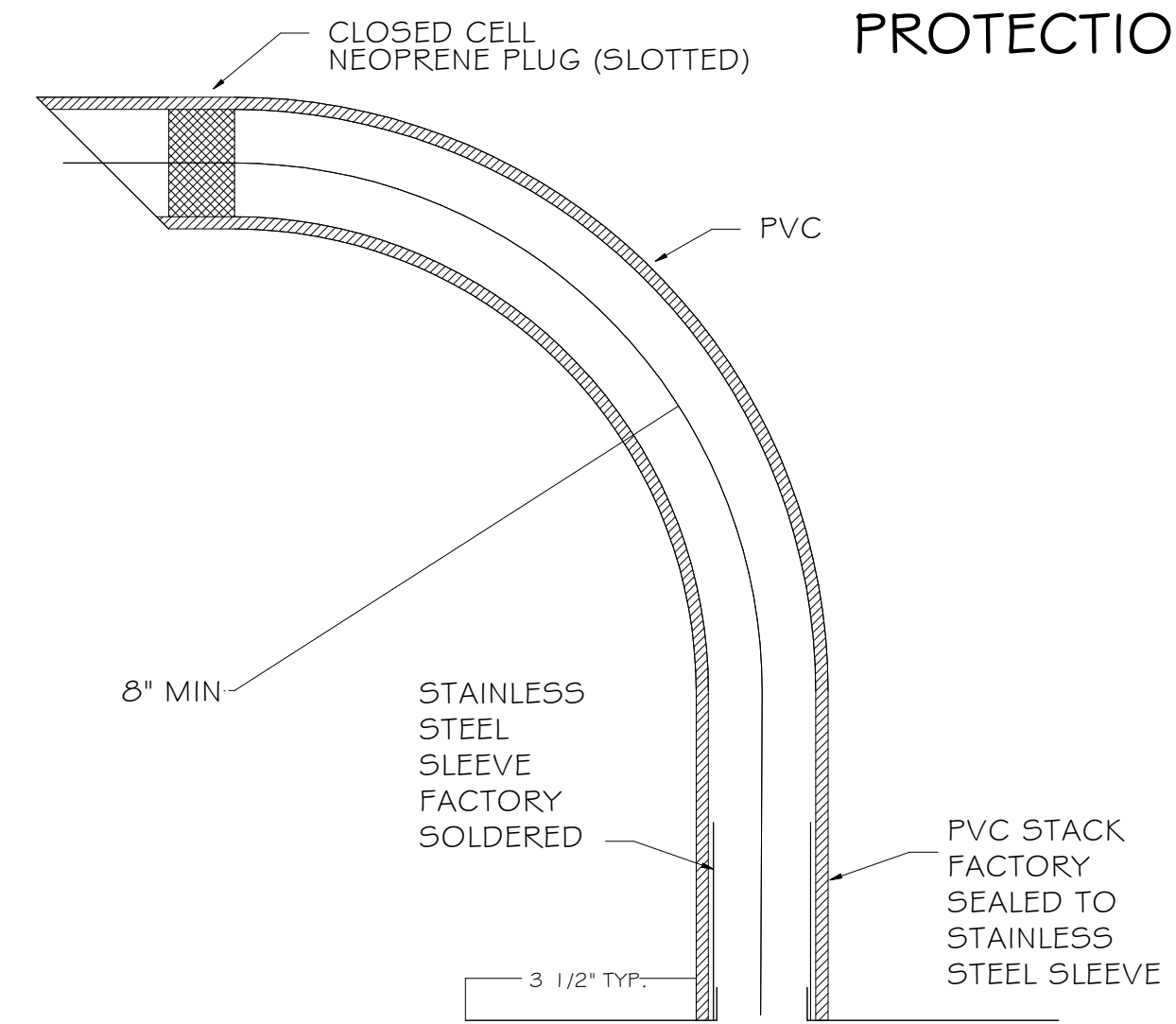

LIGHTNING PROTECTION CABLE FLASHING

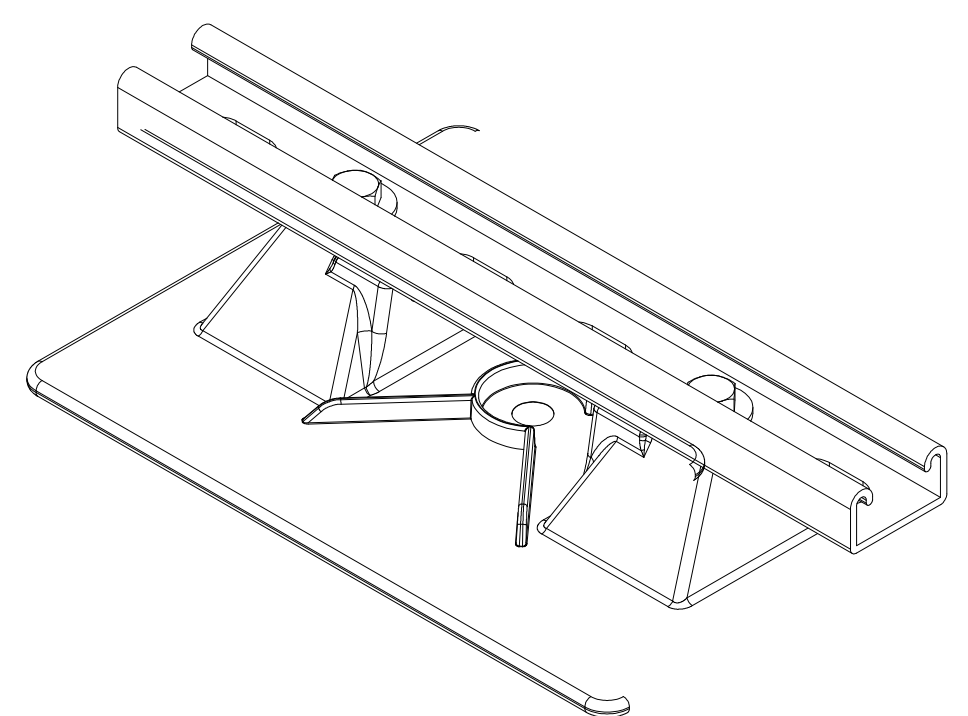

CONDUIT SUPPORT

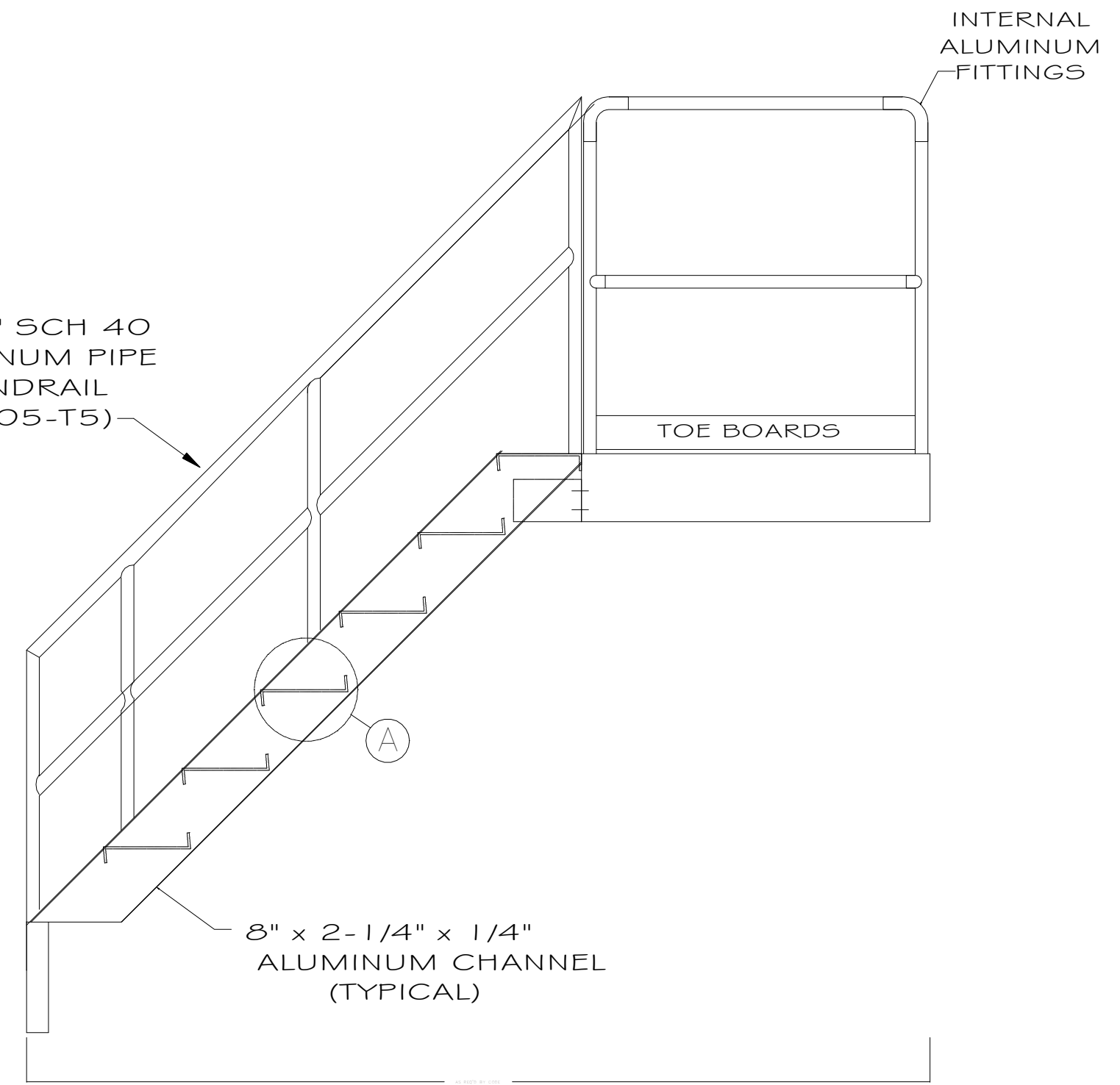

(A) ANTI-SLIP TREAD

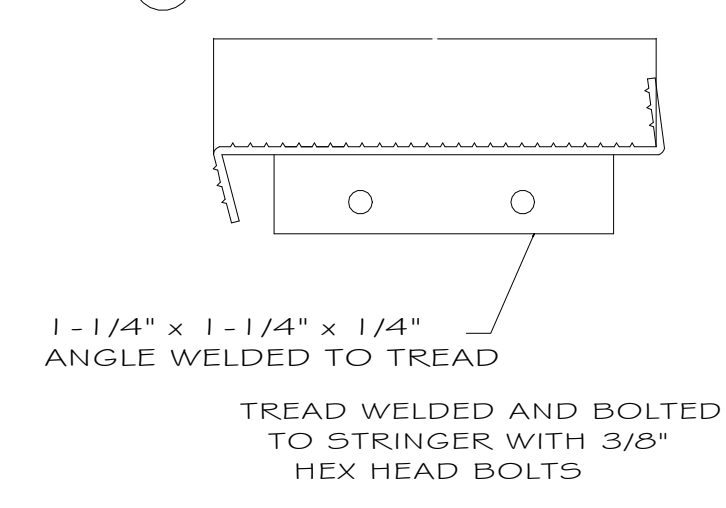

ROOF ACCESS STAIRS

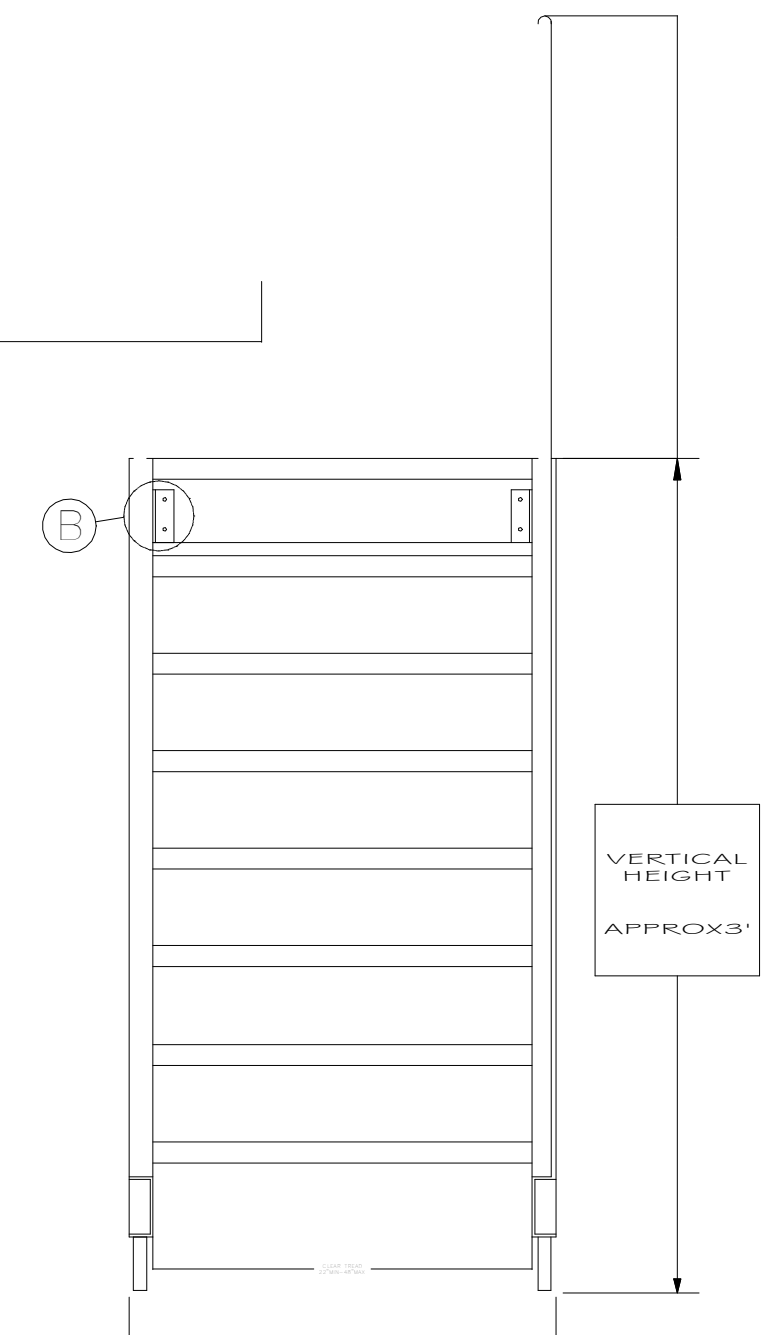

I		10/2013
No.	Revision/Issue	Date

University of South Carolina
 Callcott Social Science
 Roof Replacement (H27-6100-B)

D-2
 (Roof Details)

Prepared by
 Lyon & Associates
 Roofing and Waterproofing
 Consultants

